

NEURO 2024

第47回 日本神経科学大会

The 47th Annual Meeting of the Japan Neuroscience Society (JNS)

第67回 日本神経化学学会大会

The 67th Annual Meeting of the Japanese Society for Neurochemistry (JSN)

第46回 日本生物学的精神医学会年会

The 46th Annual Meeting of the Japanese Society of Biological Psychiatry (JSBP)

第8回 アジアオセアニア神経科学連合コンGRESS

The 8th FAONS Congress

**Deciphering the mind:
Transcending borders for the future**

2024年

7月24日水 - 27日土 July 24-27, 2024

会場
Venue

福岡コンベンションセンター
Fukuoka Convention Center

大会長
President

第47回日本神経科学大会 (JNS)
岡部 繁男 (東京大学)
Shigeo Okabe
(The University of Tokyo)

第67回日本神経化学学会大会 (JSN)
小泉 修一 (山梨大学)
Schuichi Kozumi
(University of Yamanashi)

第46回日本生物学的精神医学会年会 (JSBP)
山末 英典 (浜松医科大学)
Hidenori Yamasue
(Hamamatsu University School of Medicine)

Call for Papers /
Registration
December, 2023

NEURO2024 事務局
〒532-0003 大阪府大阪市淀川区宮原2-14-14 新大阪グランドビル6F
株式会社エー・イー企画内
TEL: 06-6350-7163 E-mail: neuro2024@aeplan.co.jp

NEURO2024 Secretariat
6th floor, Shin-Osaka Grand Bldg., 2-14-14, Miyahara, Yodogawa-ku,
Osaka, 532-0003, JAPAN
TEL: +81-6-6350-7163 E-mail: neuro2024@aeplan.co.jp

Sponsorship Prospectus

Ver.1.0

Greetings

We are excited to welcome you to NEURO2024, the joint meeting of the 47th Annual Meeting of the Japan Neuroscience Society (JNS), the 67th Annual Meeting of the Japanese Society for Neurochemistry (JSN), and the 46th Annual Meeting of the Japanese Society of Biological Psychiatry (JSBP), which will be held in Fukuoka Convention Center (Fukuoka City) from July 24th (Wed) to 27th (Sat), 2024. The last joint meeting of JNS and JSN was in 2022 as Neuro2022, and the last joint meeting of JSN and JSBP was in 2018. Based on these previous activities, NEURO2024 will introduce a new partnership between JNS and JSBP. The three Societies share the common goal of promoting the continuous development of brain science in basic, applied, and clinical research domains while maintaining the uniqueness of each society. Today, brain science covers a diverse range of topics, disciplines, and fields. Therefore, early and mid-career researchers must obtain a wide range of knowledge and skills related to biology, medicine, pharmacy, engineering, social science, and humanities. The contribution of three unique Societies, JNS, JSN, and JSBP, will benefit the participants of NEURO2024 to experience such diversity in brain science.

We are also pleased to host the 8th Federation of Asian-Oceanian Neuroscience Societies (FAONS) Congress in NEURO2024. The purpose of the Federation is to promote neuroscience research and education in the Asian Oceanian regions through the active interaction of neuroscientists between multiple countries. With its international airport connecting 22 international cities with more than 800 flights per week, Fukuoka City is an ideal place to establish a global partnership in the 8th FAONS Congress. Historically Fukuoka has been an important harbor city and prospered as a hub for diplomacy and trading with the Korean peninsula and the Eurasian continent. The King of Nakoku Gold Seal, a national treasure, was unearthed in 1784 in Fukuoka and has been taken as evidence of the diplomatic relationship between ancient China and Japan. We hope researchers with diverse backgrounds from multiple countries form new partnerships and strengthen ties with old friends in Fukuoka, the city of active international exchanges.

Exposure to exciting new findings in brain science is a top priority in NEURO2024. Brain science in the coming decade will unravel how individual neurons and glial cells interact and construct complex circuits and tissue structures, ultimately integrated into the entire brain, where the human mind resides. The accumulating knowledge about the human brain, both in health and disease, contributes to developing new strategies to predict, prevent, and cure brain or psychiatric disorders once thought to be incurable, and reduce the suffer for patients, their families and entire societies. Brain science is rapidly expanding, with its frontiers merging with physical sciences and humanities. We, aspiring brain researchers, believe brain science transcends borders of science, culture, and society for the future and advances ever closer to deciphering the human mind.

Join NEURO2024 and experience new trends in brain science!

The 47th Annual Meeting of the Japan Neuroscience Society (JNS)
Shigeo Okabe (The University of Tokyo)

The 67th Annual Meeting of the Japanese Society for Neurochemistry (JSN)
Schuichi Koizumi (University of Yamanashi)

The 46th Annual Meeting of the Japanese society of Biological Psychiatry (JSBP)
Hidenori Yamasue (Hamamatsu University School of Medicine)

NEURO2024

General information



General information

Name

NEURO2024

The 47th Annual Meeting of the Japan Neuroscience Society

The 67th Annual Meeting of the Japanese Society for Neurochemistry

The 46th Annual Meeting of the Japanese society of Biological Psychiatry

The 8th FAONS Congress

Presidents

The 47th Annual Meeting of the Japan Neuroscience Society (JNS)

Shigeo Okabe (The University of Tokyo)

The 67th Annual Meeting of the Japanese Society for Neurochemistry (JSN)

Schuichi Koizumi (University of Yamanashi)

The 46th Annual Meeting of the Japanese society of Biological Psychiatry (JSBP)

Hidenori Yamasue (Hamamatsu University School of Medicine)

Theme

Deciphering the mind: Transcending borders for the future

Date

July 24-27, 2024



General information

Venue

Fukuoka Convention Center
2-1 Sekijo-machi, Hakata-ku, Fukuoka City 812-0032
<https://www.marinemesse.or.jp/eng/>

Expected number of participants

3,000 (Incl. invitees)

Society secretariats

The Japan Neuroscience Society
Hongo Bldg., 9F, 7-2-2 Hongo, Bunkyo-ku, Tokyo 113-0033, Japan
TEL: +81-3-3813-0295

The Japanese Society for Neurochemistry
International Medical Information Center (IMIC)
Shinanomachi Rengakan, 35 Shinanomachi Shinjuku-ku, Tokyo 160-0016, Japan
TEL: +81-3-5361-7107

The Japanese Society of Biological Psychiatry
Mainichi Academic Forum Inc.
Palaceside Building, 1-1-1, Hitotsubashi, Chiyoda-ku, Tokyo 100-0003, Japan
TEL: +81-3-6267-4550

Contact

NEURO2024 Sponsorship Secretariat (c/o A&E Planning Co.,Ltd.)
Shin-Osaka Grand Bldg., 6F, 2-14-14, Miyahara, Yodogawa-ku, Osaka 532-0003, Japan
TEL: +81-6-6350-7163 E-mail: e-neuro2024@aeplan.co.jp



Organizers

Presidents

Shigeo Okabe	The University of Tokyo
Schuichi Koizumi	University of Yamanashi
Hidenori Yamasue	Hamamatsu University School of Medicine

Executive Committee Chairs

Toshihisa Ohtsuka	University of Yamanashi
Makoto Tsuda	Kyushu University
Tomoyasu Wakuda	Hamamatsu University School of Medicine

Executive Committee Members

Toshihisa Ohtsuka	University of Yamanashi
Makoto Tsuda	Kyushu University
Tomoyasu Wakuda	Hamamatsu University School of Medicine
Hiroko Bannai	Waseda University
Takeshi Inoue	Tokyo Medical University
Motoko Maekawa	Tohoku University
Manabu Makinodan	Nara Medical University
Takahiro Masuda	Kyushu University
Masanori Murayama	RIKEN
Teruhiro Okuyama	The University of Tokyo
Takuya Sasaki	Tohoku University
Hirohide Takebayashi	Niigata University
Kiyokazu Takebayashi	Hamamatsu University School of Medicine
Miho Terunuma	Niigata University
Yuji Ueno	University of Yamanashi
Hiroaki Wake	Nagoya University



Organizers

Program Committee Chairs

Yukiko Goda	OIST
Kenji Tanaka	Keio University
Hidenori Yamasue	Hamamatsu University School of Medicine

Program Committee Core Members

Yu Hayashi	University of Tokyo
Yasunori Hayashi	Kyoto University
Wataru Kakegawa	Keio University
Azusa Kamikouchi	Nagoya University
Naoko Kaneko	Doshisha University
Shinsuke Koike	University of Tokyo
Takashi Shichita	Tokyo Metropolitan Institute of Medical Science
Saori Tanaka	Nara Institute of Science and Technology

Organizing Committee Members

Yoshinori Fujiyoshi	Tokyo Medical and Dental University
Nobutaka Hirokawa	University of Tokyo
Masamitsu Iino	The University of Tokyo
Kazuhide Inoue	Kyushu University
Noriko Isobe	Kyushu University
Tomohiro Nakao	Kyushu University
Michiko Nakazato	International University of Health and Welfare
Hideyuki Okano	Keio University
Noriko Osumi	Tohoku University
Hiroaki Tomita	Tohoku University



Budget (as of April, 2023)

Income			
Item		Amount (JPY)	Remarks
1.	Registration fees	37,270,000	2,400 participants
2.	Sponsorship package	23,100,000	Platinum 2,970,000 × 2 = 5,940,000 Gold 2,530,000 × 4 = 10,120,000 Silver 1,980,000 × 4 = 7,920,000
3.	Seminar sponsorship	17,380,000	Capacity: 400-1,000 seats 2,200,000 × 4 = 8,800,000 Capacity: 200-250 seats 1,430,000 × 6 = 8,580,000
4.	Exhibition	19,448,000	Instruments 275,000 × 70 = 19,250,000 Books 33,000 × 6 = 198,000
5.	Advertising	5,300,000	Program booklet ad, Web banner etc.
6.	Donation	8,300,000	Incl. grants from various foundations, etc.
7.	Loan from the society	4,500,000	
Total		115,298,000	

Expenditure			
Item		Amount (JPY)	Remarks
1.	Preparation	<u>30,664,000</u>	
	1) Personnel	10,363,000	
	2) System-related	10,233,000	Incl. website, abstract submission/registration systems
	3) Print/Production	6,451,000	Incl. translation
	4) Communication/Transportation	3,617,000	
2.	On-site operation	<u>77,136,000</u>	
	1) Venue	26,160,000	
	2) Equipment	25,095,000	
	3) Personnel	9,500,000	
	4) Invitation	9,000,000	
	5) Meeting	3,991,000	
	6) Miscellaneous	1,590,000	
	7) Open lecture	1,800,000	
3.	Post-meeting	<u>5,726,000</u>	
4.	Reserve fund	<u>1,772,000</u>	
Total		115,298,000	



Cancellation policy

Please agree to the following policy when applying.

Cancellation of application

Once an application has been received, it cannot be cancelled unless the organizing committee recognizes it is due to a reason beyond one's control. If the organizing committee accepts a cancellation, please notify us in writing of the reason for cancellation and pay a cancellation fee based on the date your notice is received by the secretariat.

[Cancellation fee]

When a cancellation notice is received ...

by the application deadline : 50% of the amount billed

on and after the application deadline : Full amount billed

Change or Cancellation of the annual meeting

The annual meeting and the exhibition may be changed or cancelled due to natural disasters and other reasons that are beyond one's control, or for reasons that are not in the scope of the organizer's responsibility.

No compensation for damages or losses caused by such changes will be paid by the organizer to the sponsoring companies. In case the annual meeting or the exhibition is cancelled due to a reason mentioned above, the organizer will deduct preparation costs from the sponsorship fee and refund the difference to sponsor companies depending on the timing of the decision to cancel.

NEURO2024

Sponsorship opportunities



List of sponsorship opportunities

Please see the respective pages for details * All prices include tax.

■ **Sponsorship package** : JPY1,980,000~JPY2,970,000

Special packages include luncheon seminar, exhibition, web banner etc.

■ **Luncheon seminar** : JPY1,430,000~JPY1,870,000

Seminars can be held in lecture rooms during the lunchtime.

■ **Program booklet advertising** : JPY88,000~JPY275,000

Advertising in the program booklets (B5) is available.

■ **Web banner advertising on the meeting website** : JPY220,000

Web banners can be placed on the meeting website. There are multiple locations available.

■ **Screen advertising** : JPY165,000

Promotional slides and videos can be projected on the screens in lecture rooms and rest area during break times.

■ **Congress bag sponsor** : JPY330,000

Your company's logo can be printed on the congress bags which will be distributed to participants.

■ **Flyer Insert in congress bag** : JPY110,000

Flyers can be inserted in the congress bags which will be distributed to participants.

■ **Neck strap sponsor** : JPY1,650,000

Your company's logo can be printed on the neck straps which will be worn by participants.

■ **Exhibition** : Type A - JPY275,000 / Type B - JPY33,000 / Type C - JPY110,000

The exhibition will be held at the same venue as the poster presentation venue.

■ **On-demand streaming & Product introduction** : JPY330,000

Your videos can be distributed on-demand in the abstract viewing system "Confit".

NEURO2024

Sponsorship package



Sponsorship package (1)

Platinum / Gold / Silver sponsorship packages are available.

Application deadline for sponsorship package: March 15, 2024

* Please decide on the theme, chair, and speaker for luncheon seminar before applying. If these are not decided, the application will not be accepted.

Platinum

JPY2,970,000 (Incl.tax)

● The package includes

Normal price (JPY, Incl.tax)

1	Luncheon seminar	×1	First priority to choose the date & room	1,430,000~2,200,000
2	Exhibition booth (A)	×5	First priority to choose the booth location	1,375,000
3	On-demand streaming	×1		330,000
4	Web banner	×1		220,000
5	Meeting pass	×5	Incl. admission to the banquet	192,500
6	Slide projection during intermissions	×1	All lecture rooms and exhibition/posters site	165,000

Total normal price 3,722,500~4,482,500

Gold

JPY2,530,000 (Incl.tax)

● The package includes

Normal price (JPY, Incl.tax)

1	Luncheon seminar	×1	Second priority to choose the date & room	1,430,000~2,200,000
2	Exhibition booth (A)	×2	Second priority to choose the booth location	550,000
3	On-demand streaming	×1		330,000
4	Web banner	×1		220,000
5	Meeting pass	×3	Incl. admission to the banquet	115,500
6	Slide projection during intermissions	×1	All lecture rooms and exhibition/posters site	165,000

Total normal price 2,810,500~3,580,500

Silver

JPY1,980,000 (Incl.tax)

● The package includes

Normal price (JPY, Incl.tax)

1	Luncheon seminar	×1	Possible to choose the date & room	1,430,000
2	Exhibition booth (A)	×1	Possible to choose the booth location	275,000
3	Web banner	×1		220,000
4	Meeting pass	×2	Incl. admission to the banquet	77,000
5	Slide projection during intermissions	×1	All lecture rooms and exhibition/posters site	165,000

Total normal price 2,167,000



Sponsorship package (2)

Please see the respective pages for details on each benefit.

○ Meeting website: <https://neuro2024.jnss.org/en/index.html>

○ Application: Please apply via an online application form on the sponsorship page of the meeting website.

* The application cannot be cancelled unless the organizing committee recognizes it is due to a reason beyond one's control. Please check the cancellation policy for details.

○ Contact: NEURO2024 Sponsorship Secretariat (c/o A & E Planning, Co., Ltd.)
E-mail : e-neuro2024@aeplan.co.jp

* Priority in each package level will be given on a first-come-first-served basis.

* If you wish to hold a luncheon seminar as a web seminar, please contact the sponsorship secretariat.

NEURO2024

Luncheon seminar



Luncheon Seminar (1)

Luncheon seminars will be co-hosted with NEURO2024.

Venue: Lecture room or Online (Web seminar using Zoom)

Date & Time: July 24 - 26, 2024 at lunch time

Length: 50 minutes

Language: Japanese or English

Fee:

Date	Time *Tentative	Capacity *Tentative	Fee (Incl.tax)
July 24	12:00 - 12:50	400 – 1,000 seats	JPY2,200,000
		200 - 250 seats	JPY1,430,000
July 25	12:00 - 12:50	400 – 1,000 seats	JPY2,200,000
		200 - 250 seats	JPY1,430,000
July 26	12:00 - 12:50	400 – 1,000 seats	JPY2,200,000
		200 - 250 seats	JPY1,430,000

● **Option: On-site + Online (Live streaming)**

Live streaming is available for above fee + JPY550,000 (Incl.tax), if you wish live streaming besides on-site.

3-6 seminars per day will be held in parallel. It is subject to change depending on the number of applications.

Please note that the date & room of each seminar will be decided by the organizing committee with reference to the preferences of co-hosts.

* The time slot may be changed for scheduling reasons.

* If you wish to hold a luncheon seminar as a web seminar only, please contact the sponsorship secretariat. (Only web seminar: JPY1,430,000 (Incl. tax))



Luncheon Seminar (2)

- Application: Please apply via an online application form on the sponsorship page of the meeting website.
 - * The application cannot be cancelled unless the organizing committee recognizes it is due to a reason beyond one's control. Please check the cancellation policy for details.

- Application deadline: Advance reservation available March 15, 2024
 - * Please decide on the theme, chair, and speaker for luncheon seminar before applying. If these are not decided, the application will not be accepted.

- Payment: An invoice will be sent after application. Please make a payment before the due date written on the invoice.
 - *Please cover the bank transfer fees.

- Disclosure of information:
 - We agree that the sponsors disclose their contributions.

- Contact: NEURO2024 Sponsorship Secretariat (c/o A & E Planning, Co., Ltd.)
E-mail : e-neuro2024@aeplan.co.jp

- Remarks
 - Lecture room facilities
 - Fees for standard audio-visual equipment (projector, screen, microphone, etc.) and staff in charge of video, audio, and lighting are included in the seminar fee.
 - Also, 2 meeting passes to participate in the meeting program are to be provided.
 - If any other equipment such as video and audio recording is required, charges will be incurred separately. Please contact the secretariat.

 - Program
 - Program will be organized by the executive committee and informed to the seminar co-hosts from the secretariat.

 - What is NOT included in the seminar fee
 - The following fees are NOT included in the seminar fee.
 - Actual cost will be charged by the secretariat after the meeting.

 - Box lunch with packet drink (green tea) for participants * Not required for web seminar
 - Please make an arrangement for lunch as a seminar will be held during lunchtime.
 - Box lunch with packet drink (green tea): JPY1,500 /box *tentative
 - The necessary number of box lunches will be decided by the co-host after the application deadline.
 - The secretariat will then place an order for the total number of all.



Luncheon Seminar (3)

- Options

- ① Operating staff (announcement, timekeeping, distributing handouts and lunch, guide, etc.)

- *This will be arranged separately from the operating staff for the meeting.

- ② Honorarium and travel expenses for speaker and chair

- ③ Signage/Display: Signboards in front of the room etc.

- ④ Additional equipment: video and audio recording / simultaneous interpretation / facilities for anteroom, etc.

- ⑤ Anteroom: room charge, food, and drink

- ⑥ Operating expenses

- * If you order any of above options, a 10% service fee will be charged in addition to the total amount of option fees.

- An advance reservation system for luncheon seminar tickets will be available for participants.

- The information of participants who made a reservation will be provided to each seminar co-host.

- The schedule and procedure will be notified from the secretariat after the application.

- Acquisition of Personal Information and Use of the System

- Please read the following terms and conditions regarding acquisition of personal information and use of the system, and check the box on the application form.

- 1. Resale of acquired personal information is prohibited.

- 2. Personal information acquired shall be used only within the company unless otherwise agreed by an individual.

- 3. If an individual refuses to provide information or communicate, the use of his/her personal information shall be stopped.

- 4. Appropriate precautionary measures should be taken by assigning a personal information manager to prevent the loss or leakage of acquired personal information.

- 5. If personal information that is clearly seems to be erroneous is obtained in any way, it will not be used and will be deleted.

- 6. Other appropriate measures shall be taken in accordance with the Act on the Protection of Personal Information.

NEURO2024

Advertising

Pocket program advertising

Web banner advertising on the meeting website

Screen advertising

Congress bag sponsor

Flyer Insert in congress bag

Neck strap sponsor



Advertising (1)

■ Pocket program advertising

- Advertising medium: NEURO2024 Pocket Program
- Book size, Printing method: B5 (257 mm height×182 mm width), approx. 40 pages
Offset printing (Front cover: 4 colors / Body: Black and White), Perfect binding
- Circulation: 3,000
- Subject of distribution: Meeting participants
- Budget: JPY4,000,000
- Rate: *Incl.tax

Page	Size	Color	Rate	No. of slots
Cover 4 (Back cover)	B5 : 1 page	4 colors	JPY275,000	1
Cover 2 (Inside front)	B5 : 1 page	Black and White	JPY165,000	1
Cover 3 (Inside back)	B5 : 1 page	Black and White	JPY132,000	1
Back matter 1 page	B5 : 1 page	Black and White	JPY88,000	Up to 16

Please note that ads for back matter will be assigned by the organizer.

- Application: Please apply via an online application form on the sponsorship page of the meeting website.
- Application deadline: April 26, 2024
- Ad submission deadline: May 10, 2024
- Ad size: 225 mm height×150 mm width
- Ad requirements: Print-ready data (Please attach a print sample.)
- Format
 1. Adobe illustrator
Please outline all fonts, and embed all images. Also, please specify your OS and the version of Illustrator used for creating the ad.
Proofreading will be performed by the printer. Please note that a proof sheet will not be sent to you.
 2. PDF
Please outline all fonts, and embed all images. If MS-Word or MS-PowerPoint is used for creating the ad, please make sure to specify the application used.
Please note that submitted data may not be accepted.
- Ad submission: Please send an ad data to the sponsorship secretariat by e-mail.
- Payment: An invoice will be sent after publishing. Please make a payment by the due date written on the invoice.
- Disclosure of information: We agree that the sponsors disclose their contributions.



Advertising (2)

■ Web banner advertising on the meeting website

- Advertising medium: Website of NEURO2024
- Advertising form: Web banner advertising
- URL: <https://neuro2024.jnss.org/en/index.html>
Open in July, 2023
- Number of banners: 10 *tentative
- Display method: Top of the website
Please ask the sponsorship secretariat for details.
Random display - banners appear at random when the website is visited.
- Rate: JPY220,000 /banner (Incl.tax)
- Application: Please apply via an online application form on the sponsorship page of the meeting website.
- Placement period: Applications are accepted any time after the website is launched in August, 2023.
Placement is guaranteed until 1 month after the meeting.
- Banner size: Height 80 pixels × Width 228 pixels
- Format: GIF (Animation GIF, Infinite loop are acceptable) /JPEG/PNG etc.
- Banner submission: Please send a banner data to the sponsorship secretariat by e-mail.
Also, please send the URL to be linked to the banner as well.
- Payment: A banner will be placed within 7 business days after receipt, and then, an invoice will be sent. Please make a payment by the due date written on the invoice.
- Disclosure of information: We agree that the sponsors disclose their contributions.
- Contact: NEURO2024 Sponsorship Secretariat (c/o A & E Planning, Co., Ltd.)
E-mail : e-neuro2024@aeplan.co.jp



Advertising (3)

■ Screen advertising

- Advertising medium: Screen used for NEURO2024
- Advertising form: Screen advertising
- Details: Promotional slides and videos will be projected on the screens in lecture rooms and rest area during break times.
- Number of spots: 10 *tentative
- Display method: Loop, 20 seconds per 1 spot
- Rate: JPY165,000 /spot (Incl.tax)
- Application deadline: May 31, 2024
- Application: Please apply via an online application form on the sponsorship page of the meeting website.
- Projection period: During NEURO2024 (July 24 – 27, 2024)
- Format: Microsoft PowerPoint (Resolution: XGA / Aspect ratio: 4:3)
- Ad submission: Please send an ad data to the sponsorship secretariat by e-mail.
- Payment: An invoice will be sent before the meeting. Please make a payment by the due date written on the invoice.
- Disclosure of information: We agree that the sponsors disclose their contributions.
- Contact: NEURO2024 Sponsorship Secretariat (c/o A & E Planning, Co., Ltd.)
E-mail : e-neuro2024@aeplan.co.jp



Advertising (4)

■ Congress bag sponsor

- Advertising medium: NEURO2024 congress bag
- Advertising form: Ad printed on congress bag
- Details: Your company's logo will be printed on the congress bags which will be distributed to participants.
- Number of spots: 2
- Rate: JPY330,000 /spot (Incl.tax)
- Application deadline: May 10, 2024
- Application: Please apply via an online application form on the sponsorship page of the meeting website.
- Format: Adobe illustrator, Print-ready data
- Ad submission: Please send an ad data to the sponsorship secretariat by e-mail.
- Payment: An invoice will be sent before the meeting. Please make a payment by the due date written on the invoice.
- Disclosure of information: We agree that the sponsors disclose their contributions.
- Contact: NEURO2024 Sponsorship Secretariat (c/o A & E Planning, Co., Ltd.)
E-mail : e-neuro2024@aeplan.co.jp



Advertising (5)

■ Flyer insert in congress bag

- Advertising medium: Flyer insert in NEURO2024 congress bag
- Advertising form: Flyer
- Details: Flyers will be inserted in the congress bags which will be distributed to participants.
- Number of flyers: 5 *Only 1 flyer per company
- Rate: JPY110,000円 /flyer (Incl.tax)
- Application deadline: May 31, 2024
- Application: Please apply via an online application form on the sponsorship page of the meeting website.
- Size of flyer: A4, 1 page
No rules for printing and colors (Both are acceptable: double/single sided printing, 4 colors/black and white)
- Flyer submission: Please send 3,000 copies of the flyer to the designated address given by the sponsorship secretariat at a later date.
- Payment: An invoice will be sent before the meeting. Please make a payment by the due date written on the invoice.
- Disclosure of information: We agree that the sponsors disclose their contributions.
- Contact: NEURO2024 Sponsorship Secretariat (c/o A & E Planning, Co., Ltd.)
E-mail : e-neuro2024@aeplan.co.jp



Advertising (6)

■ Neck strap sponsor

- Advertising medium: NEURO2024 neck strap
- Advertising form: Ad on neck strap
- Details: Your company's logo will be printed on the neck straps which will be worn by participants.
- Number of slot: 1
- Rate: JPY1,650,000円 (Incl.tax)
- Application deadline: May 10, 2024
- Application: Please apply via an online application form on the sponsorship page of the meeting website.
- Format: Adobe illustrator, Print-ready data
- Ad submission: Please send an ad data to the sponsorship secretariat by e-mail.
- Payment: An invoice will be sent before the meeting. Please make a payment by the due date written on the invoice.
- Disclosure of information: We agree that the sponsors disclose their contributions.
- Contact: NEURO2024 Sponsorship Secretariat (c/o A & E Planning, Co., Ltd.)
E-mail : e-neuro2024@aeplan.co.jp

NEURO2024

Exhibition



Exhibition (1)

■ Exhibition

- Schedule: July 23, 2024 14:00 - 17:00 (Installation)
 July 24, 2024 9:00 - 17:00
 July 25, 2024 9:00 - 17:00
 July 26, 2024 9:00 - 17:00 (Dismantling 17:00 -)
*The above schedule is subject to change. Please be sure to check the exhibitor's manual which will be sent at least 1 month prior to the meeting.
- Venue: Marine Messe Fukuoka Hall B
- Applicable products & services:
Medical and life science research related instruments, reagents, disposables, computer systems including software, database, etc., contract services, introduction/recruitment of universities and research institutions, other research related services, books, and translation service.
Applications from company that does not have products or services mentioned above will not be accepted.
- Number of booths: 100
- Application deadline: April 26, 2024
- Application: Please apply via an online application form on the sponsorship page of the meeting website.
(1) A confirmation e-mail will be sent after you have submitted an application.
(2) Then, another e-mail confirming the receipt of your application will be sent from the sponsorship secretariat.
Your application will be complete by receiving (1) and (2) mentioned above. Please note that applicants that are not eligible for application will be notified later after due consideration. When you have any troubles applying online, please contact the sponsorship secretariat.
- Payment: An invoice will be sent before the meeting. Please make a payment by the due date written on the invoice.
* Please make sure to inform us if the payment will not be made by the due date on the invoice due to unforeseen circumstances. Otherwise, your application will be cancelled and a cancellation charge will be incurred. Please refer to the cancellation policy page for details.
- Disclosure of information:
We agree that the sponsors disclose their contributions.
- Contact: NEURO2024 Sponsorship Secretariat (c/o A & E Planning, Co., Ltd.)
E-mail : e-neuro2024@aeplan.co.jp



Exhibition (2)

- Booth assignment: After application is closed, booths will be assigned in consideration of the type, shape, and weight of the exhibits and the number of booths applied for, and notify the exhibitors in the exhibitor's manual. Please note that exhibitors' briefing will not be held.

* If you wish to set up a booth side-by-side with your affiliate or associate companies, please inform the sponsorship secretariat by the application deadline.
- Use of display table: Each booth is equipped with a display table. Please enter the number of booths that do not need a display table in the application form.
- Exhibit management: Please note that the exhibitors are responsible for the management of their own exhibits, and the secretariat will not compensate for any damages caused by thefts, losses, fire or inevitable accidents during the exhibition.
- Others: Distribution of flyers, catalogs, sample products, etc., other than in front of your own booth (inside and outside the buildings where the exhibition and lectures take place) is prohibited. As many exhibitors are expected to participate in the exhibition, your cooperation would be highly appreciated. However, there will be some exceptions such as cases approved by the Executive Committee.
- Use of exhibition fee: Part of exhibition fee will be used for arranging "Stamp rally"(Prizes etc.) which is to be held at the exhibition hall. We welcome your sponsorship for prizes as well. If you are interested in, please contact the secretariat.

Exhibition (3)

○ Booth type and Fee

◆ Type A: JPY275,000 /booth (Incl.tax)

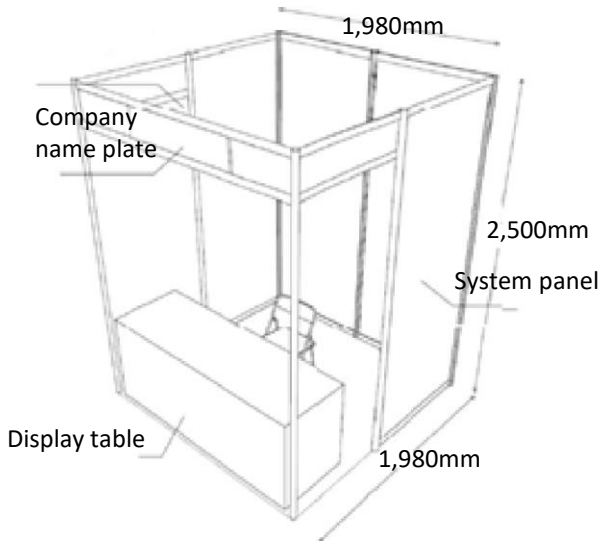

○ Applicable products & services:

Medical and life science research related instruments, reagents, disposables, computer systems including software, database, etc., and contract services.

○ Booth size: W1,980×D1,980×H2,500 (mm)

○ Furniture:

Display table covered with a white cloth (W1,800×D900×H approx.720(mm)), Company name plate, Lighting (FL40W), 1 chair (The no. of chairs depends on the no. of booths applied for.)

○ System panels are used for booths.

Pushpins and nails are not available on the panels to attach panel or poster.

○ 4 exhibition staff badges per booth will be provided.

○ **1 meeting pass to participate in the meeting program will be provided.**

◆ Type B: JPY33,000 /booth (Incl.tax)

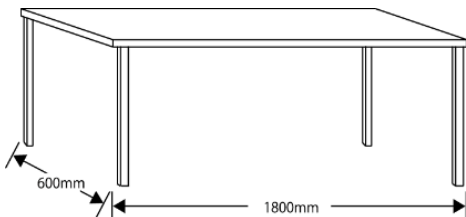

○ Applicable products & services:

Related books, translation services, etc.

○ Booth size: W1,800×D600 (mm)

○ Furniture:

Display table covered with a white cloth (W1,800×D600 (mm)), 1 chair, Company name plate

○ 4 exhibition staff badges per booth will be provided.

Exhibition (4)

◆ Type C: JPY110,000 /booth (Incl.tax)

* The specifications of the booth will be the same as for Type A, but the eligible applicants are different.

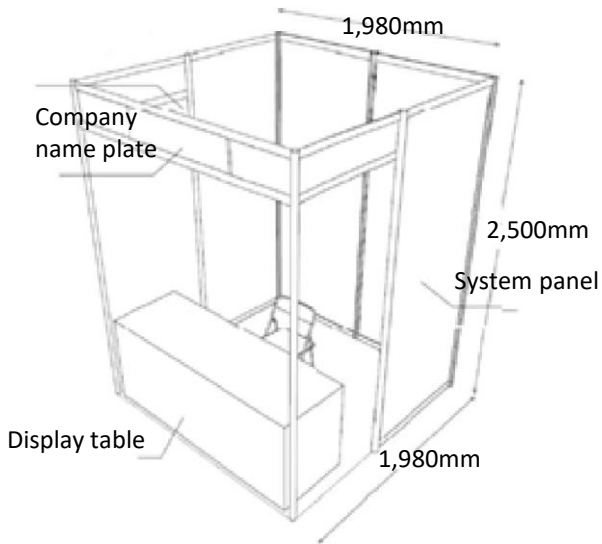

○ Eligible applicants:

Academic institutions such as universities, public institutions, etc.

○ Booth size: W1,980×D1,980×H2,500 (mm)

○ Furniture:

Display table covered with a white cloth (W1,800×D900×H approx.720(mm)), Company name plate, Lighting (FL40W), 1 chair (The no. of chairs depends on the no. of booths applied for.)

○ System panels are used for booths.

Pushpins and nails are not available on the panels to attach panel or poster.

○ 4 exhibition staff badges per booth will be provided.

○ **1 meeting pass to participate in the meeting program will be provided.**

Application is required for the use of electricity (100V).

The electricity bill and costs for electrical installation work should be paid by the exhibitor.

Electricity bill

Up to 500W JPY33,000 (Incl.tax)

501W - 1KW JPY38,500 (Incl.tax)

2 outlets are provided per 1KW. Additional outlets and earth terminal require extra charges.

*For the use of over 1KW, JPY16,500 (Incl. tax) per 1KW will be added.

*200V power supply (single-/three-phase) needs another installation work and can be rather expensive.

If needed, please apply for electricity along with the booth.

NEURO2024

On-demand streaming

&

Product introduction

■ On-demand streaming

- Details: Your company-owned videos can be distributed on-demand in the online conference system "Confit" where the participants view the timetable, the abstracts etc. Also, your product introduction can be posted with text, image and link.
*The link to Youtube will be embedded..
- Streaming period: July 17 – August 31, 2024 *tentative
- Applicable products & services: Same as the exhibition. Please see the Exhibition section for details.
- Fee: JPY330,000 /slot (Incl.tax)
- Application deadline: May 31, 2024
- Application: Please apply via an online application form on the sponsorship page of the meeting website.
- Payment: An invoice will be sent before the meeting. Please make a payment by the due date written on the invoice.
- Disclosure of information: We agree that the sponsors disclose their contributions.
- Contact: NEURO2024 Sponsorship Secretariat (c/o A & E Planning, Co., Ltd.)
E-mail : e-neuro2024@aeplan.co.jp
- Image

